

# H300 Basic Soft Start.

## HHI Drives Europe Installation and Maintenance Manual.



# H300 Basic Soft Start.

<b>Contents</b>	<b>1</b>	<b>Safety.</b>
	<b>2</b>	<b>Installation.</b>
	2.1	Line and Motor Connections.
	2.2	Control and Fan Supply.
	2.3	Run Input.
	2.4	Run Output Relay.
	2.5	Top of Ramp Output Relay.
	<b>3</b>	<b>Settings.</b>
	3.1	DIL Switches.
	3.2	Potentiometers.
	<b>4</b>	<b>Typical Applications.</b>
	4.1	Basic Motor Starter.
	4.2	Motor Starter with Bypass Contactor.
	4.3	Motor Starter and Power Economiser.

HHI Drives Europe.  
PO Box 2091.  
Bolton  
BL5 2ZS  
U.K.

Tel. 08452 300 501  
Email <http://www.hhidrives.com/contact.htm>  
Web [www.hhidrives.com](http://www.hhidrives.com)

## **H300 Basic Soft Start.**

### **1 Safety.**

#### **1.1 Earth.**

Ensure that the unit is earthed. The units are provided with M6 studs at the top of the chassis. The studs are marked with an earth label. Check with local wiring regulations to determine the size of cable required.

#### **1.2 Power Cables.**

The supply is taken to the line connections at the top of the unit. Ensure that the feeder cables are appropriately protected by an upstream fuse or circuit breaker. Ensure that the supply cables are correctly co-ordinated with respect to the earth conductor.

#### **1.3 Fuses.**

The supply cable must have some form of upstream protection. Three aR fuses optionally fitted in the soft start only for the purpose of protecting the thyristors in the event of a dead short on the output. Replace the fuses with the same current rating and speed. These fuses are not for the purpose of protecting cables.

### **2 Installation.**

#### **2.1 Line and Motor Connections.**

In essence the soft start connects three ac power lines to a three-phase load, normally a motor. The soft start is not phase rotation sensitive, but your application may be. Phase rotation is not altered by the soft start. It is important to connect the supply to the line terminals of the unit. The line terminals are labelled "LINE" and are at the top. Similarly the load connections must go to the load end of the soft start. These terminals are labelled "LOAD", and are at the bottom.

#### **2.2 Control and Fan Supplies.**

A control supply is required to operate the electronics of the unit. A terminals block supports the two transformer primaries. The primaries may

## H300 Basic Soft Start.

be wired in parallel for 115V operation, or series for 230V operation. The load is less than 5VA.

For larger units, 30kW and above, force ventilation is installed. The two fans are 115Vac, and may be connected series or parallel to suit either 115V or 230V control supply.

### 2.3 Run Input. (J10)

The run input is an isolated pair of terminals. A voltage across the terminals will enable the soft start in the start / run mode. A lack of voltage at these terminals will set the soft start in the stopping / stop mode.

The terminals will accept 110Vac to 230Vac as a run signal. Alternatively a 24Vdc voltage may be applied. Ensure the voltage for the stop condition is less than 6V.

Some soft starts will latch a run signal. A separate relay will be required if momentary stop and start buttons are used. Typical circuits are shown at the end of this manual.

### 2.4 Run Output Relay. (J9)

The run relay is energised when the soft start is running. The unit is running when the soft start is in any condition other than stopped. The amber lamp indicates running.

In the following description of the terminal functions “Normal” means that the unit is de-energised, stopped or at fault.

Terminal	11	Common.
Terminal	14	Normally open.
Terminal	12	Normally closed.

### 2.5 Top of Ramp Output Relay. (J8)

The top of ramp relay is energised when the soft start is enabled and has completed the run-up procedure. The output is particularly applicable to the use of a bypass contactor.

The relay is also energised during optimised operation. A bypass contactor is definitely not used in optimised mode.

## H300 Basic Soft Start.

In the following description of the terminal functions “Normal” means that the unit is de-energised, running up, running down, stopped, or at fault.

Terminal	21	Common.
Terminal	24	Normally open.
Terminal	22	Normally closed.

### 3 Settings.

#### 3.1 DIL Switches. (SW1,2,3)

The three pcb mounted switches are labelled “1,2,3” on the body of the switch. The “on” position is also shown. Switches 2 and 3 give a permutation of four possible modes of operation.

Switch 1 has influence with one combination of SW2,3

No optimisation and no protection (SW2 and SW3 off)

Without optimisation the soft start will ramp up the output voltage to match the supply voltage. At top of ramp a bypass contactor may be closed to short out the soft start losses. Without protection the soft start will not detect any faults other than overload during initial start-up.

No optimisation, but protection during ramp-up (SW2 on, SW3 off)

Without optimisation the soft start will ramp up the output voltage to match the supply voltage. At top of ramp a bypass contactor may be closed to short out the soft start losses. With protection during start-up, the soft start is able to detect phase loss or a shorted thyristor. By switching off the protection at top of ramp the soft start is not tripped by a bypass contactor which “looks” like a shorted thyristor. The overload function is defeated when the bypass contactor closes.

No optimisation, and full time protection (SW2 off, SW3 on)

Without optimisation the soft start will ramp up the output voltage to match the supply voltage. A bypass contactor is not recommended in this mode. The soft start may trip because it “sees” the bypass contact as a shorted

## H300 Basic Soft Start.

thyristor. Without a bypass contactor the overload function remains active at all times.

Optimised with full time protection (SW2, 3 both on) SW1 active.

With optimisation mode selected the soft start will ramp up to full output voltage, and then begin to optimise the output voltage. During optimisation the output voltage is reduced in order to minimise motor losses when the motor is only lightly loaded.

If the voltage is too low the motor losses will increase, and the soft start gradually searches for the optimum operating voltage. The search function takes time. The rate of search is set by SW1.

Optimising rate (SW1 on slow, off normal)

The load on a motor may change during operation. In some cases the load may change gradually as in a ventilation system. A conveyor system load may change more suddenly.

### 3.2 Potentiometers.

Start Time 0-240 seconds (RV1)

At start-up the output voltage rises to 85% of the line supply. RV1 sets the time in which the voltage rises from 85% to full output.

Adjusting the pot when the starter is running will have no effect.

The new setting will only be effective at the next start.

Please note that 240 seconds is four minutes, and during commissioning it can seem as though nothing is happening. If in doubt check the output voltage.

Stop Time 0-240 seconds (RV2)

When the starter is disabled the voltage begins to ramp down to 75% of the line voltage. RV2 sets the time it takes to ramp down.

Adjusting the pot when the starter is running will have no effect.

## **H300 Basic Soft Start.**

The new setting will only be effective at the next start.

Please note that 240 seconds is four minutes, and during commissioning it can seem as though nothing is happening. If in doubt check the output voltage.

### **Current Limit 1-6 x FLC (RV3)**

RV3 sets the current limit of the starter as a factor of the full load current of the starter. The full load current of the starter can be found on the rating plate of the starter.

The setting is read only when the unit is stopped.

# H300 Basic Soft Start.

## 4 Typical Applications.

### 4.1 Basic Motor Starter.

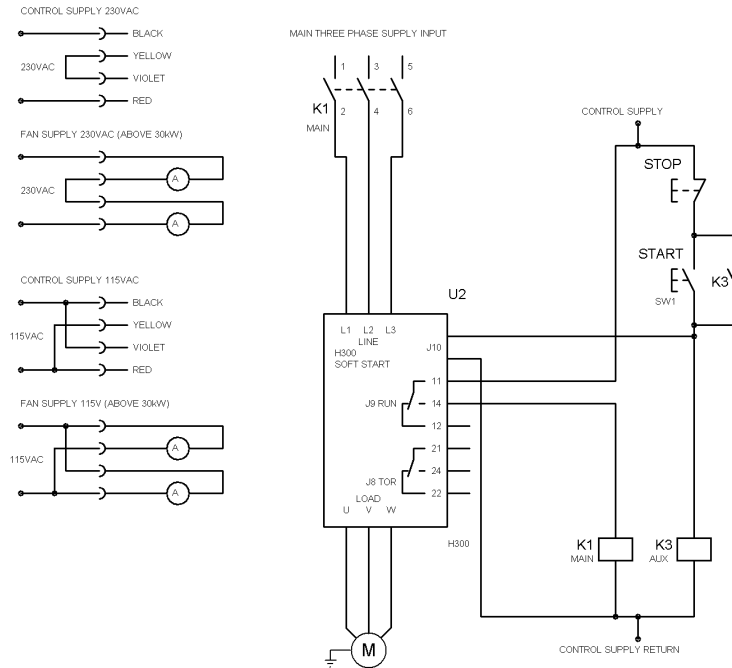

OPERATION H300

START

MOMENTARY START BUTTON SW1 BRINGS IN AUXILIARY RELAY K3. K3 LATCHES SW1 SOFT START ENABLED AT J10 BY K3 COIL. SOFT START RUN RELAY BRINGS IN MAIN K1 AND SOFT START BEGINS TO RAMP UP OUTPUT

STOP

MOMENTARY ACTION BUTTON SW2 CUTS SUPPLY TO K3. K3 DE-ENERGISES, AND VOLTAGE IS REMOVED FROM RUN INPUT J10 OF SOFT START. SOFT START BEGINS TO RAMP DOWN. SOFT START IS DISABLED AT BOTTOM OF RAMP AND K1 IS RELEASED.

SOFT START REQUIRES CONTROL SUPPLY AND FAN SUPPLY ABOVE 230W. NOT SHOWN. FAN AND CONTROL SUPPLY MAY BE CONFIGURED FOR 230VAC OR 115VAC.

J10 ACCEPTS 12/24V DC OR 110/230 VAC

ABBREVIATIONS

TOR = TOP OF RAMP

H300 Without Bypass Contactor
H300 Soft Start Basic Circuit
DRG. NO. HH06AP05 ISS 0 DATE 06AP05

Switch Settings.

Full Output on Run.

SW1 Don't care.

SW2 Off.

SW3 On.

Optimised Output on Run.

SW1 To suit variations in load.

SW2 On.

SW2 On.



# H300 Basic Soft Start.

## 4.2 Motor Starter with Bypass Contactor.

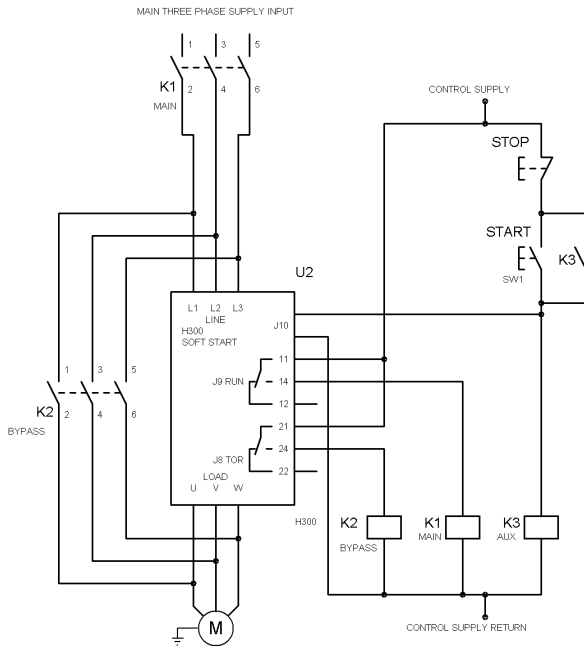

OPERATION H300

MOMENTARY START BUTTON SW1 BRINGS IN AUXILIARY RELAY K3. K3 LATCHES SW1 SOFT START ENABLED AT J10 BY K3 COIL. SOFT START RUN RELAY BRINGS IN MAIN K1

TOP OF RAMP CONTACTS 21,24 BRING IN K2 BYPASS CONTACTOR

SOFT START REQUIRES CONTROL SUPPLY AND FAN SUPPLY ABOVE 23kW

NOT SHOWN  
FAN AND CONTROL SUPPLY MAY BE CONFIGURED FOR 230VAC OR 115VAC

J10 ACCEPTS 12/24V DC OR 110/230 VAC

ABBREVIATIONS

TOR = TOP OF RAMP

H300 With Bypass Contactor
H300 Soft Start with Bypass Contactor
DRG. NO. HH04AP05 ISS 0 DATE 04AP05

### Switch Settings.

SW1 Don't care.

SW2 On.

SW3 Off.

# H300 Basic Soft Start.

## 4.3 Motor Starter and Power Economiser.

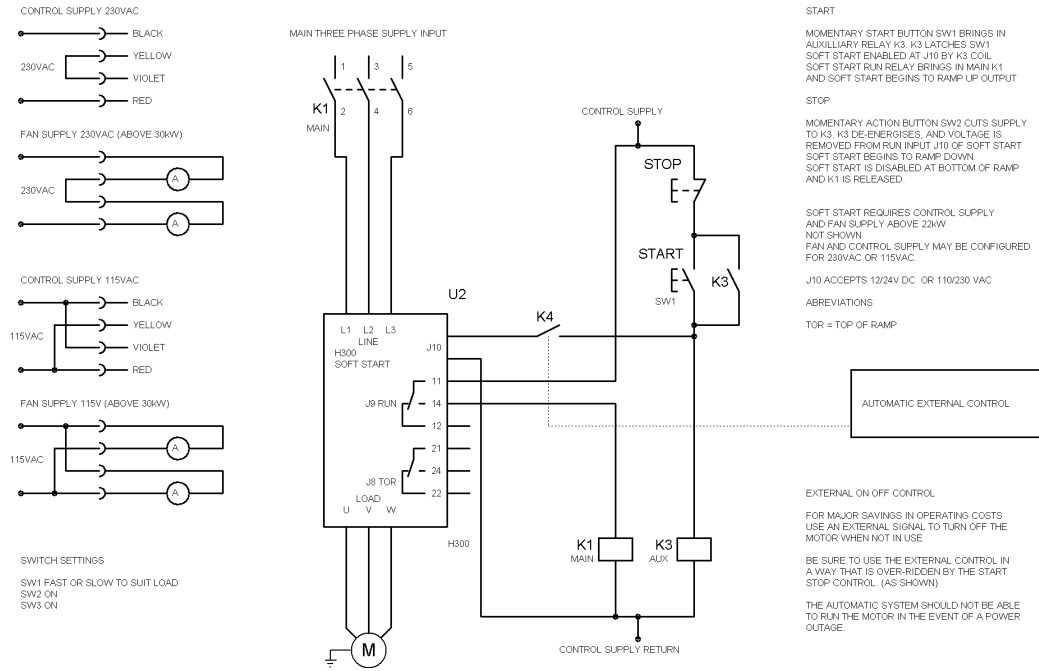

**OPERATION H300**

**START**

MOMENTARY START BUTTON SW1 BRINGS IN AUXILIARY RELAY K3. K3 LATCHES SW1 SOFT START ENABLED AT J10 BY K3 COIL. SOFT START RUN RELAY BRINGS IN MAIN K1 AND SOFT START BEGINS TO RAMP UP OUTPUT

**STOP**

MOMENTARY ACTION BUTTON SW2 CUTS SUPPLY TO K3. K3 DE-ENERGISES, AND VOLTAGE IS REMOVED FROM RUN INPUT J10 OF SOFT START. SOFT START BEGINS TO RAMP DOWN. SOFT START IS DISABLED AT BOTTOM OF RAMP AND K1 IS RELEASED.

SOFT START REQUIRES CONTROL SUPPLY AND FAN SUPPLY ABOVE 23kW NOT SHOWN. FAN AND CONTROL SUPPLY MAY BE CONFIGURED FOR 230VAC OR 115VAC.

J10 ACCEPTS 12/24V DC OR 110/230 VAC

**ABBREVIATIONS**

TOR = TOP OF RAMP

**EXTERNAL ON OFF CONTROL**

FOR MAJOR SAVINGS IN OPERATING COSTS USE AN EXTERNAL SIGNAL TO TURN OFF THE MOTOR WHEN NOT IN USE

BE SURE TO USE THE EXTERNAL CONTROL IN A WAY THAT IS OVER-RIDDEN BY THE START STOP CONTROL. (AS SHOWN)

THE AUTOMATIC SYSTEM SHOULD NOT BE ABLE TO RUN THE MOTOR IN THE EVENT OF A POWER OUTAGE.

H300 Economiser Plus
H300 Soft Start Economiser Plus Circuit
DRG. NO. HH06AP051 ISS 0 DATE 06AP05